

# Lafferty Equipment Manufacturing, Inc. Installation & Operation Instructions

Model # 973750 · 517 Sanitizer

## REQUIREMENTS

### Chemical Concentrate

<b>Water</b>	
Temperature	up to 160°F
Pressure	35 to 125 PSI
Flow	5.4 GPM @ 40 PSI
Supply Line	3/4"
<b>Hose</b>	3/4" ID x 50'
<b>Nozzle</b>	40100

## OPTIONS

<b>Stainless Steel Hose Rack</b>	
Large	# 224150
<b>Stainless Steel Jug Racks</b>	
2 ½ Gallon (8 ½" x 10 ½")	# 224210
5 Gallon (12" x 12")	# 224215
5 Gallon Round Locking	# 224216
<b>Safe Flow Lid™ for 1 Gallon Jugs</b>	
Lid, Suction Tube, and Strainer	# 709101
<b>Alternate Sanitizer Check Valve - Viton Standard</b>	
Check Valve, Chemical, PP/EPDM, 1/4"	# 491311

## WEIGHT & DIMENSIONS

<b>Single Package</b>	
Shipping Weight	23 lbs.
Shipping Dimensions	28" x 19" x 8"



**Lafferty**  
EQUIPMENT MANUFACTURING INC.

[www.laffertyequipment.com](http://www.laffertyequipment.com)

501-851-2820



**WARNING! READ ALL  
INSTRUCTIONS BEFORE  
USING EQUIPMENT!**

## OVERVIEW

The 517 Sanitizer is a high volume venturi injection system that uses standard city water pressure (35 - 125 PSI) to draw and blend chemical concentrate into the water stream. Precision metering tips are used to create the lean ratios required for no-rinse sanitizing in food plants. The solution is projected through the discharge hose and fan nozzle as a 5.4 GPM, heavy spray for fast and efficient coverage.

**SAFETY & OPERATIONAL PRECAUTIONS**

- When connecting to a potable water supply follow all local codes for backflow prevention.
- **WARNING: Severe damage to your facility, or contamination of your potable water supply, can occur without proper backflow prevention.**
- For proper performance do NOT modify, substitute nozzle, hose diameter or length.
- Manufacturer assumes no liability for the use or misuse of this unit.
- Wear protective clothing, gloves and safety goggles when working with chemicals.
- Always direct the discharge away from people and electrical devices.
- For pressures over 100 PSI, remove the discharge valve or lower pressure.
- Never leave inlet ball valves on when unit is not in use.
- Follow the chemical manufacturer's safe handling instructions.
- NEVER mix chemicals without first consulting chemical manufacturer.

**TO INSTALL (REFER TO DIAGRAM ON NEXT PAGE)**

If you are connecting to a potable water supply follow all local codes for backflow prevention.

1. Mount the unit to a suitable surface above the chemical supply to prevent siphoning.
2. Connect the discharge hose(s) as shown in the diagram.
3. Flush any new plumbing of debris before connecting water.
4. Connect water supply. If water piping is older, or has known contaminants, install a water filter.

Set the chemical dilution ratio by threading one of the color coded metering tips into each chemical check valve. See chemical labels for dilution ratio recommendation or consult your chemical supplier.

- For the strongest dilution ratio do NOT install a colored metering tip.
- The dilution ratios in the metering tip chart are based on water thin chemicals with a viscosity of 1CPS.
- **Thicker chemicals will require a larger tip than the ratios shown in the chart.**
- Application results will ultimately determine final tip color.
- Select the tip color that is closest to your desired chemical strength and thread it into the tip holder. DO NOT OVER TIGHTEN.
- Push the chemical tube over the check valve barb and place the strainer in the chemical concentrate.

**TO OPERATE**

**Always** make sure the discharge ball valve is closed or pointed in a safe direction before turning water on. Ball valve can be shut off at any time during operation but **should not be left unattended for long periods of time.**

1. Open the inlet ball valve then open the discharge ball valve to begin application.
2. Make final metering tip adjustments based on application results.
3. When application is completed, close the discharge ball valve, return to the unit and close the inlet ball valve. Re-open the discharge ball valve to relieve pressure in hose then close the discharge ball valve. If applicable rinse the work surface before solution dries.

**METERING TIP SELECTION**

METERING TIP COLOR	FL-OZ PER MIN	DILUTION RATIO @ 40 PSI
Brown	0.56	1234:1
Clear	0.88	785:1
Bright Purple	1.38	501:1
White	2.15	321:1
Pink	2.93	236:1
Corn Yellow	3.84	180:1
Dark Green	4.88	142:1
Orange	5.77	120:1
Gray	6.01	115:1
Light Green	7.01	99:1
Med. Green	8.06	86:1
Clear Pink	9.43	73:1
Yellow Green	11.50	60:1
Burgundy	11.93	58:1
Pale Pink	13.87	50:1
Light Blue	15.14	46:1
Dark Purple	17.88	39:1
Navy Blue	25.36	27:1
Clear Aqua	28.60	24:1
Black	50.00	14:1
No Tip Ratio Up To:		11:1

The dilution ratios above are approximate values. Due to chemical viscosity, actual dilution ratios may vary.

FORMULA
GPM × 128 ÷ Dilution ratio = fl-oz/min

**FLOW RATES**

PSI	GPM
35	5.05
40	5.40
50	6.04
60	6.61
70	7.14
80	7.64
90	8.10
100	8.54
110	8.95
120	9.35
125	9.55

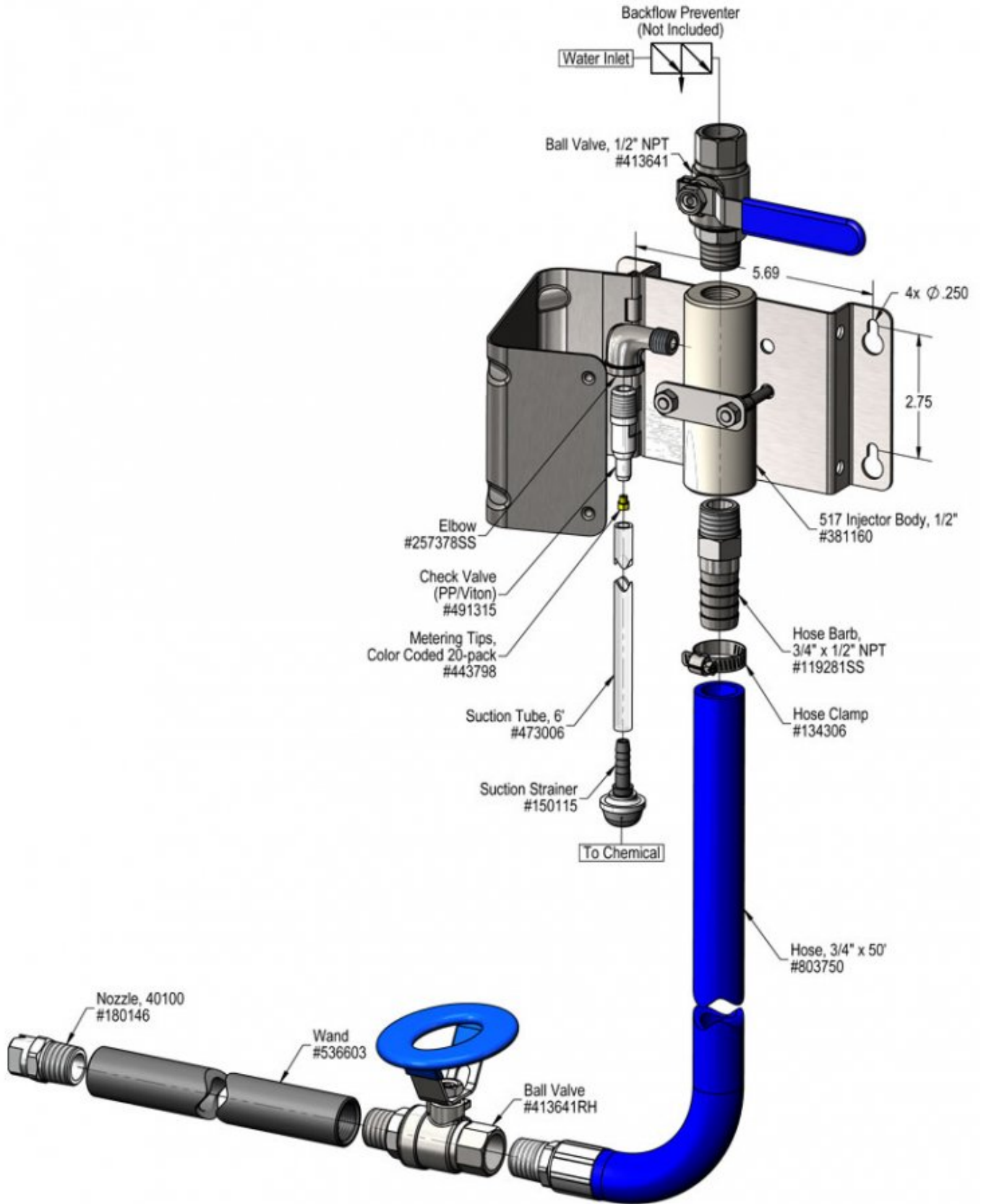

Problem	Possible Cause / Solution	
	Startup	Maintenance
A) Unit will not draw chemical	1, 4, 5, 6, 7	8, 9, 10, 11, 12, 13, 14
B) Dilution too weak	2, 4, 5	8, 9, 10, 11, 12, 13, 14
C) Dilution too strong	3	14
D) Water backing up into chemical container		8

Possible Cause / Solution	
Startup	Maintenance
<ol style="list-style-type: none"> <li>1. <b>Inlet or discharge ball valves not completely open</b> <ul style="list-style-type: none"> <li>◦ Completely open both ball valves.</li> </ul> </li> <li>2. <b>Not enough chemical - metering tip too small</b> <ul style="list-style-type: none"> <li>◦ Install larger metering tip.</li> </ul> </li> <li>3. <b>No metering tip installed or metering tip too large</b> <ul style="list-style-type: none"> <li>◦ Install smaller metering tip.</li> </ul> </li> <li>4. <b>Chemical tube not immersed in chemical or chemical depleted</b> <ul style="list-style-type: none"> <li>◦ Immerse tube or replenish.</li> </ul> </li> <li>5. <b>Discharge hose too long for available water pressure, kinked or wrong size</b> <ul style="list-style-type: none"> <li>◦ Straighten the hose or replace hose.</li> </ul> </li> <li>6. <b>Nozzle size too small (SEE REQUIREMENTS)</b></li> <li>7. <b>Water pressure or water volume too low/inlet piping too small causing poor chemical pick up</b> <ul style="list-style-type: none"> <li>◦ Increase water pressure or water volume</li> </ul> </li> </ol>	<ol style="list-style-type: none"> <li>8. <b>Chemical check valve stuck or failed</b> <ul style="list-style-type: none"> <li>◦ Clean or replace.</li> </ul> </li> <li>9. <b>Chemical strainer or metering tip partially blocked</b> <ul style="list-style-type: none"> <li>◦ Clean or replace chemical strainer and/or metering tip.</li> </ul> </li> <li>10. <b>Chemical tube stretched out or pin hole/cut in chemical tube</b> <ul style="list-style-type: none"> <li>◦ Cut off end of tube or replace tube.</li> </ul> </li> <li>11. <b>Vacuum leak in chemical pick-up connections</b> <ul style="list-style-type: none"> <li>◦ Tighten the connection.</li> </ul> </li> <li>12. <b>Water strainer clogged or missing/injector inlet orifice clogged</b> <ul style="list-style-type: none"> <li>◦ Clean or replace strainer; check/clean inlet orifice for obstructions. DO NOT DRILL OUT.</li> </ul> </li> <li>13. <b>Hard water scale or chemical build-up may have formed in the injector body causing poor or no chemical pick-up</b> <ul style="list-style-type: none"> <li>◦ Follow Preventive Maintenance instructions below, using hot water and/or de-scaling acid. When there is no draw at all, carefully remove fittings and soak entire injector body in de-scaling acid.</li> </ul> </li> <li>14. <b>More than one chemical ball valve is open</b> <ul style="list-style-type: none"> <li>◦ 2-Way and 3-Way models only</li> </ul> </li> </ol>

**PREVENTIVE MAINTENANCE:** When the unit will be out of service for extended periods, place chemical tube(s) in water and flush the chemical out of the unit to help prevent chemical from drying out and causing build-up. Periodically check and clean chemical strainer and replace if missing.

